

Features

- 3.5V to 20V DC Operation Voltage
- Temperature Compensation
- Wide Operating Voltage Range
- Open-Collector Pre-Driver
- 25mA Maximum Sinking Output Current
- Reverse Polarity Protection
- Lead Free Package: SIP-3L (Note 1) and SC59 (Commonly known as SOT23 in Asia)
- SC59-3L: Available in "Green" Molding Compound (No Br, Sb)
- Lead Free Finish / RoHS Compliant (Note 2)

General Description

ATS137 is a switched Hall-Effect IC, which is for contactless switching applications. The device includes an on-chip Hall voltage generator for magnetic sensing, an amplifier that amplifies the Hall voltage, a Schmitt trigger to provide switching hysteresis for noise rejection, and an open-collector output. The bandgap regulator allows a wide operating voltage range. ATS137 is rated for operating temperature range from -20°C to 85°C and voltage range from 3.5V to 20V.

Applications

- VCD/DVD Loader, CD/DVD ROM
- Cover Detector
- Speed Measurement
- Home Appliances
- Home Safety

Ordering Information

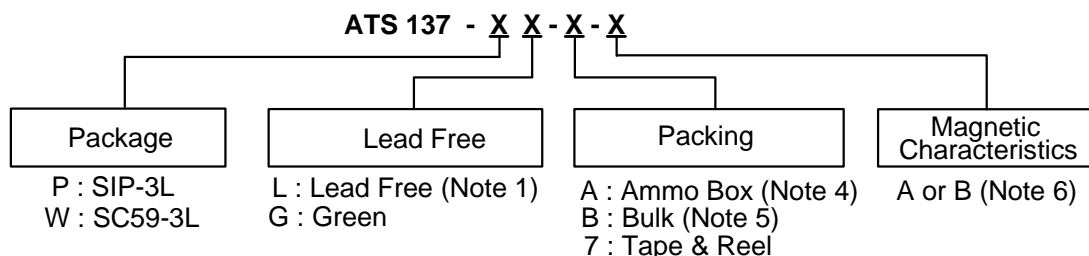

Device	Package Code	Packaging (Note 3)	Bulk		7" Tape and Reel		Ammo Box		Magnetic Characteristics (Note 6)
			Quantity	Part Number Suffix	Quantity	Part Number Suffix	Quantity	Part Number Suffix	
ATS137-PL-A-A	P	SIP-3L	NA	NA	NA	NA	4000/Box	-A	A
ATS137-PL-A-B	P	SIP-3L	NA	NA	NA	NA	4000/Box	-A	B
ATS137-PL-B-A	P	SIP-3L	1000	-B	NA	NA	NA	NA	A
ATS137-PL-B-B	P	SIP-3L	1000	-B	NA	NA	NA	NA	B
ATS137-WL-7-A	W	SC59-3L	NA	NA	3000/Tape & Reel	-7	NA	NA	A
ATS137-WG-7-A	W	SC59-3L	NA	NA	3000/Tape & Reel	-7	NA	NA	A

- Notes:
1. SIP-3L is available in "Lead Free" product only.
 2. EU Directive 2002/95/EC (RoHS). All applicable RoHS exemptions applied, see *EU Directive 2002/95/EC Annex Notes*.
 3. Pad layout as shown on Diodes Inc. suggested pad layout document AP02001, which can be found on our website at <http://www.diodes.com/datasheets/ap02001.pdf>.
 4. Ammo Box is for SIP-3L Spread Lead.
 5. Bulk is for SIP-3L Straight Lead.
 6. Please refer the Magnetic Characteristics table, B is available in SIP-3L package only.

Pin Assignment

(1) SIP-3L

(Top View)

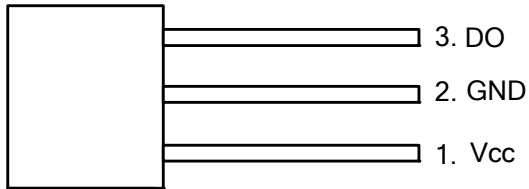

(2) SC59-3L

(Top View)

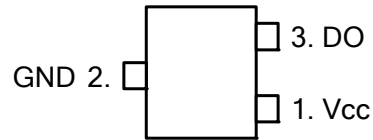

Pin Descriptions

Name	Pin #	Description
Vcc	1	Positive Power Supply
GND	2	Ground
DO	3	Digital Output

Typical Circuit

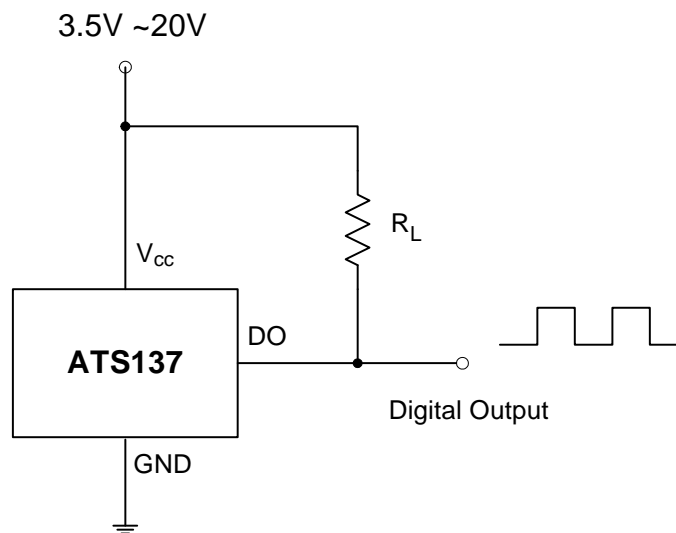

Functional Block Diagrams

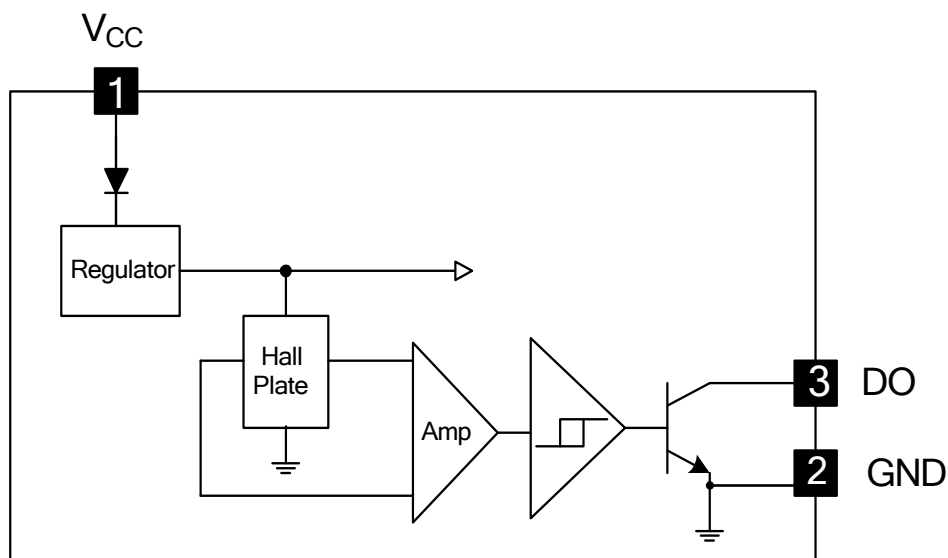

Absolute Maximum Ratings ($T_A = 25^\circ\text{C}$)

Symbol	Characteristics	Values	Unit
V_{CC}	Supply Voltage	20	V
V_{RCC}	Reverse V_{CC} Polarity Voltage	-20	V
B	Magnetic Flux Density	Unlimited	
V_{ce}	Output "OFF" Voltage	30	V
I_C	Output "ON" Current	Continuous	25
T_{ST}	Storage Temperature	-65~+150	$^\circ\text{C}$
$T_{J(MAX)}$	Maximum Junction Temperature	150	$^\circ\text{C}$
P_D	Package Power Dissipation	SIP-3L	550
		SC59-3L	230

Recommended Operating Conditions

Symbol	Characteristic	Conditions	Min	Max	Unit
V_{CC}	Supply Voltage	Operating	3.5	20	V
T_A	Operating Ambient Temperature	Operating	-20	85	$^\circ\text{C}$

Electrical Characteristics ($T_A = +25^\circ\text{C}$)

Symbol	Characteristic	Test Conditions	Min	Typ.	Max	Units
$V_{ce(SAT)}$	Output Saturation Voltage	$V_{CC} = 14\text{V}, I_{CC} = 20\text{mA}$	-	300	700	mV
I_{ceX}	Output Leakage Current	$V_{ce} = 14\text{V}, V_{CC} = 14\text{V}$	-	<0.1	10	μA
I_{CC}	Supply Current	$V_{CC} = 20\text{V}$, Output Open	-	5	10	mA
t_r	Output Rise Time	$V_{CC} = 14\text{V}, R_L = 820\Omega,$ $CL = 20\text{pF}$	-	0.3	1.5	μs
t_f	Output Falling Time	$V_{CC} = 14\text{V}, R_L = 820\Omega,$ $CL = 20\text{pF}$	-	0.3	1.5	μs

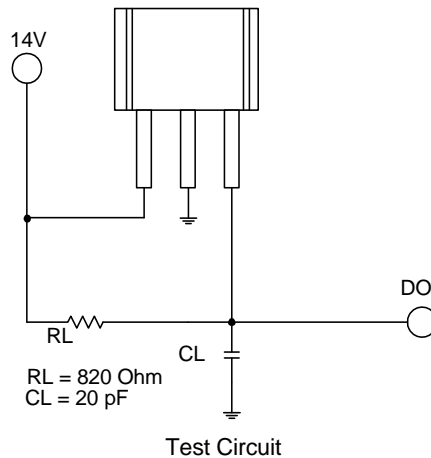
Test Circuit

Magnetic Characteristics ($T_A = 25^\circ\text{C}$)

(1mT = 10 Gauss)

A grade

Symbol	Characteristics	Min	Typ.	Max	Unit
Bops(south pole to brand side)	Operation Point	-	-	100	Gauss
Brps(south pole to brand side)	Release Point	10	-	-	Gauss
$B_{hy}(B_{opx} - B_{rpx})$	Hysteresis	-	80	-	Gauss

B grade (for SIP-3L only)

Symbol	Characteristics	Min	Typ.	Max	Unit
Bops(south pole to brand side)	Operation Point	-	-	130	Gauss
Brps(south pole to brand side)	Release Point	10	-	-	Gauss
$B_{hy}(B_{opx} - B_{rpx})$	Hysteresis	-	80	-	Gauss

Application Information

Operating principle:

ATS137 is a three-pin Hall Effect switch IC which can turn magnetic flux variety to digital output signal. In other words, it is an interface from magnetic system to an electrical one by Hall effect. The illustrations are shown in Fig.1.

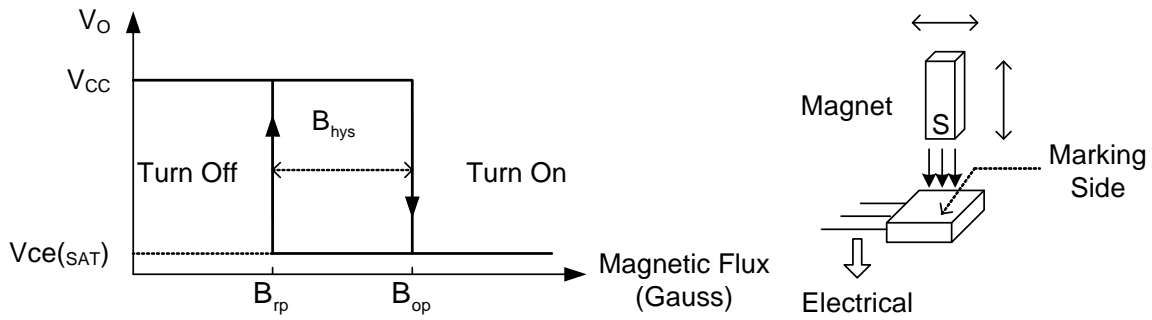

Fig.1 Hall-Effect Switch

Output driver is open-collector topology and maximum sink current (I_{sink}) is 25mA. The illustrated circuit is shown as Fig. 2.

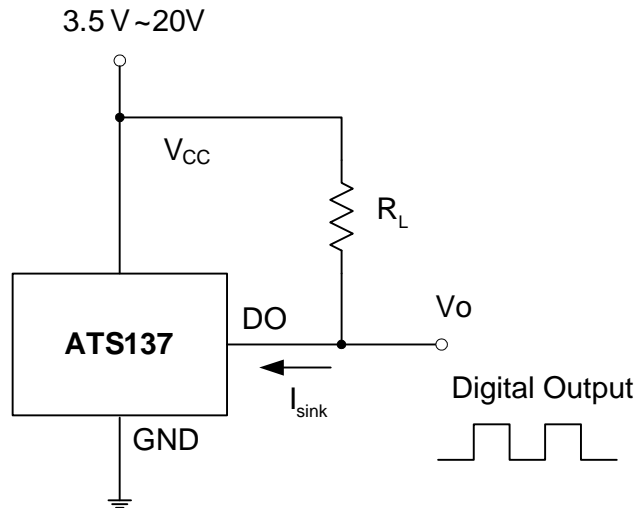

Fig.2 Application Circuit

Application Information (Continued)

V_o will turn on (low) if the S magnetic flux larger than the operation point (B_{op}), and turns off whenever the magnetic flux is removed and lower than the release point (B_{rp}). The related waveforms are shown in Fig.3.

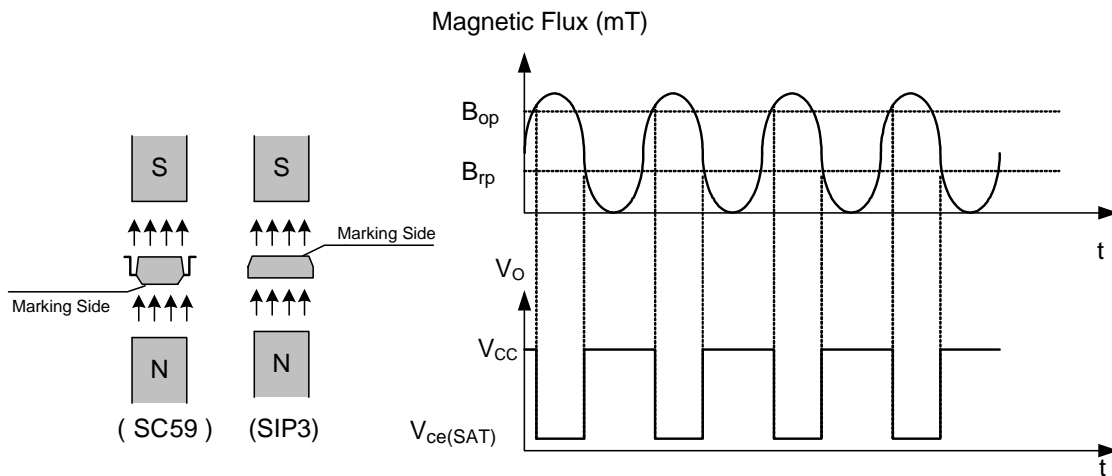

Fig.3 V_o and Magnetic Flux Variety

The major applications are for contactless switching and shown as follows:

- VCD/DVD loader, CD/DVD ROM: Detect if the tray is opened or closed.
- Cover detector (open/close): Cellular phone cover detector, refrigerator door detector, microwave oven door sensor, etc.
- Home safety: instead of reed relay to detect the situation of door/window.
- Due to contactless and without mechanical contact point, its reliability and life cycle are much longer than reed relay. In addition, its switching speed is much faster than mechanical devices.

Performance Characteristics

(1) SIP-3L

T_A (°C)	25	50	60	70	80	85	90	95	100
P _D (mW)	550	440	396	352	308	286	264	242	220
T_A (°C)	105	110	115	120	125	130	135	140	150
P _D (mW)	198	176	154	132	110	88	66	44	0

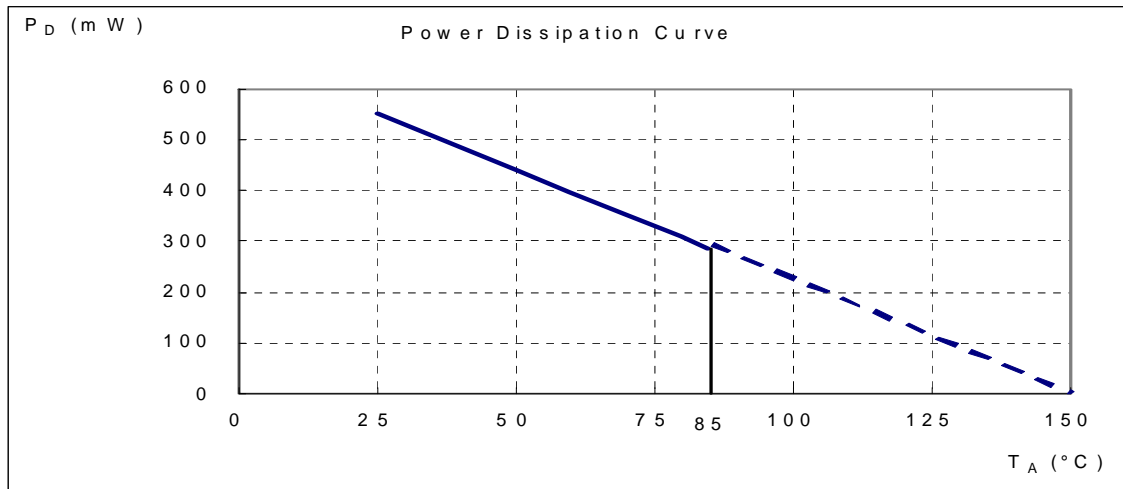

(2) SC59-3L (commonly known as SOT23 in Asia)

T_A (°C)	25	50	60	70	80	85	90	100	110	120	125	130	140	150
P _D (mW)	230	184	166	147	129	120	110	92	74	55	46	37	18	0

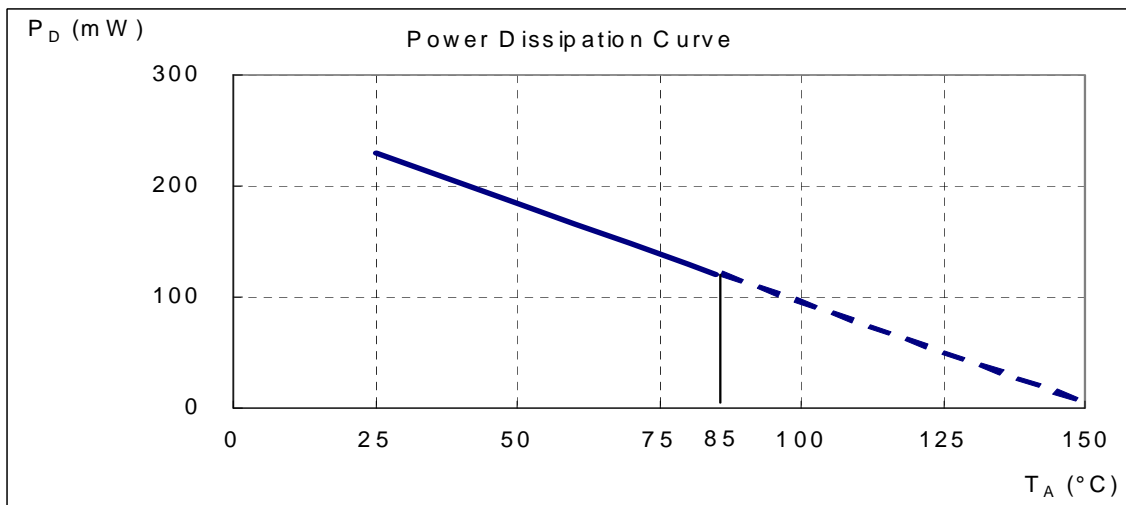

Marking Information

(1) SIP3-3L

(Top View)

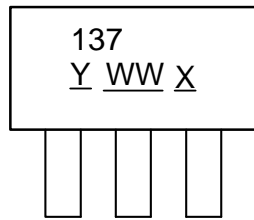

Y : Year : "7" = 2007
"8" = 2008
WW : Nth Week 01~52
X : Internal code
a~z : Lead Free

(2) SC59 (Commonly known as SOT23 in Asia)

(Top View)

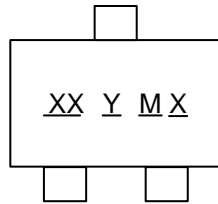

XX : JA : ATS137
Y : Year 0~9
M : Month A~L
X : Internal code
A~Z : Green
a~z : Lead Free

Part Number	Package	Identification Code
ATS137	SC59-3L	JA

Package Information (All Dimensions in mm)

(1) Package Type: SIP-3L for Bulk pack

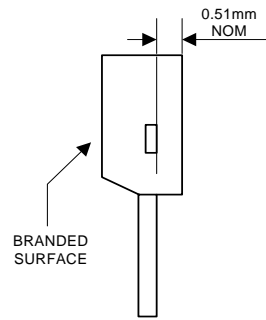

Active Area Depth

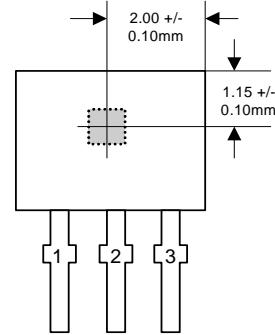

Sensor Location

Package Dimension

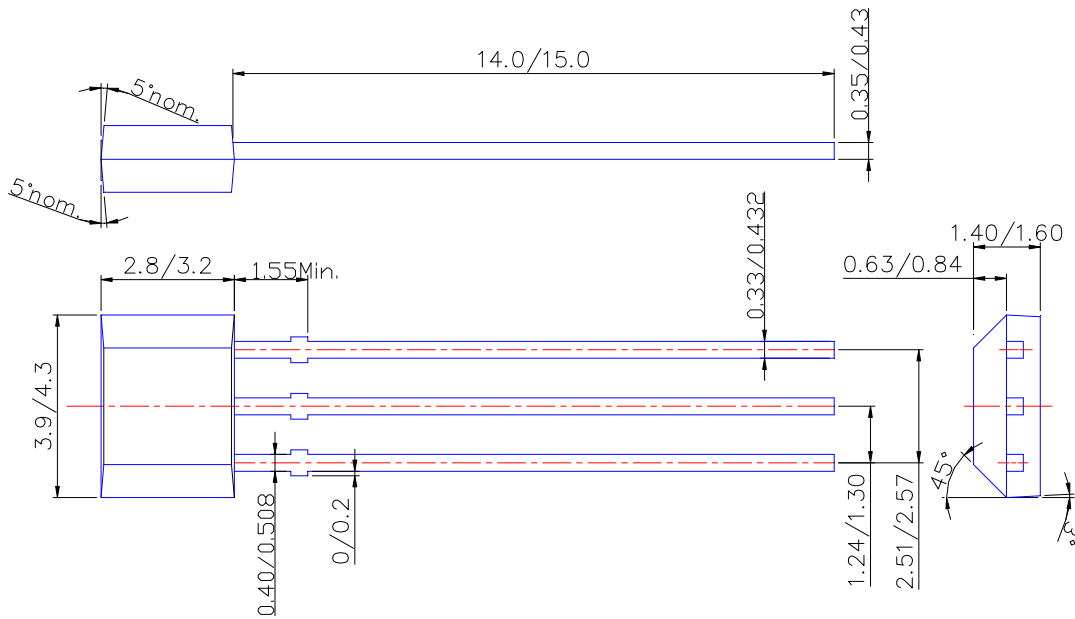

Package Information (Continued)

(2) Package Type: SIP-3L for Ammo pack

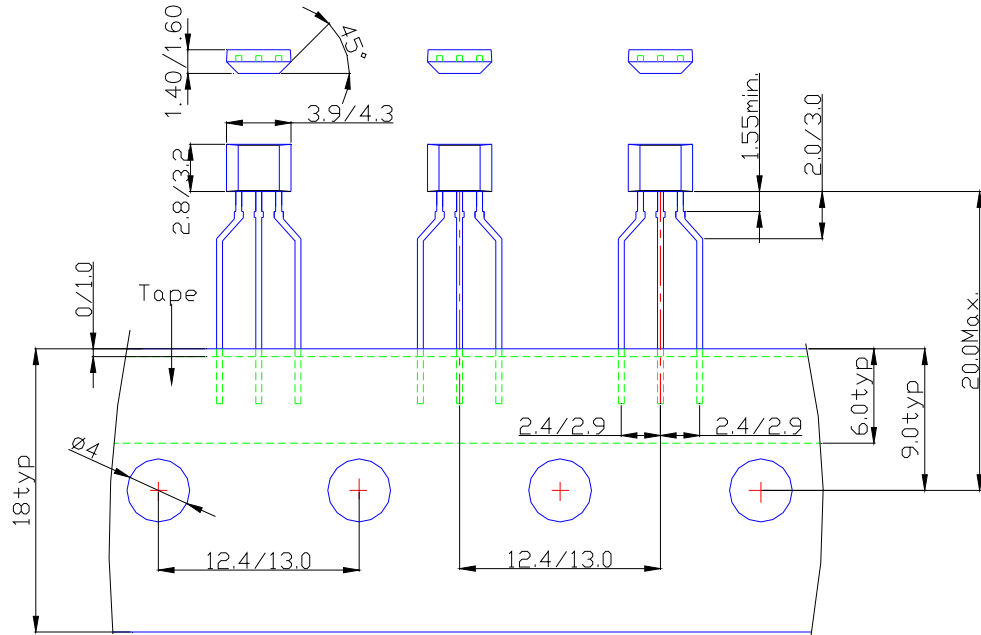

(3) SC59 (Commonly known as SOT23 in Asia)

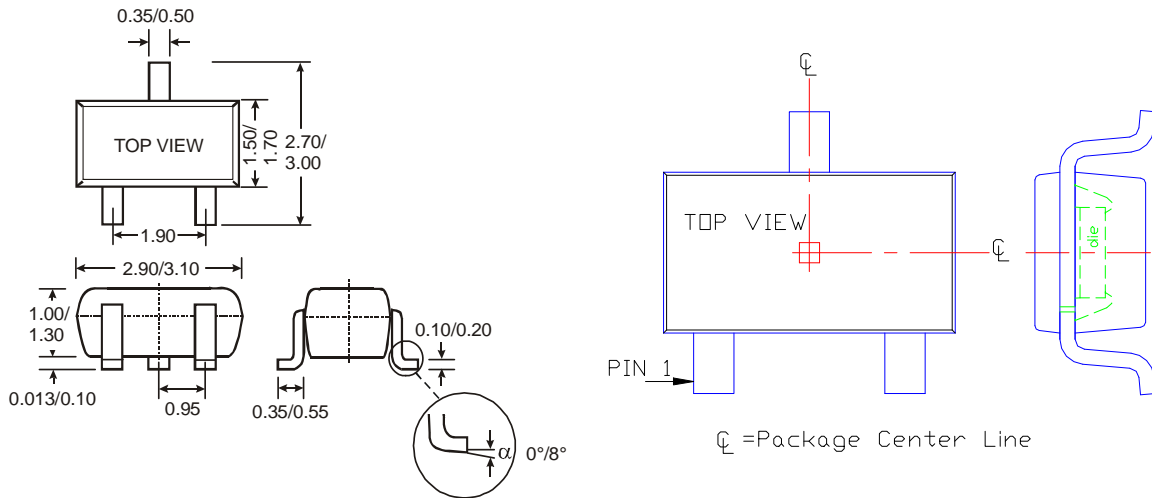

IMPORTANT NOTICE

Diodes Incorporated and its subsidiaries reserve the right to make modifications, enhancements, improvements, corrections or other changes without further notice to any product herein. Diodes Incorporated does not assume any liability arising out of the application or use of any product described herein; neither does it convey any license under its patent rights, nor the rights of others. The user of products in such applications shall assume all risks of such use and will agree to hold Diodes Incorporated and all the companies whose products are represented on our website, harmless against all damages.

LIFE SUPPORT

Diodes Incorporated products are not authorized for use as critical components in life support devices or systems without the expressed written approval of the President of Diodes Incorporated.